



Pelican International Replacement Parts Installation Instructions

Contents

Procedure.....	Page
A) Hub and Crank Replacement	2
B) Crank Bushing Replacement	3
C) Pedal Replacement	4
D) Hub Blade Replacement	4
E) Steering Rod Replacement	5
F) Rudder Blade / Post Replacement	6
G) Thru-hull Bushing Replacement.....	7
H) Steering Elbow Replacement	8

Copyright SmallWaterCraft LLC All rights reserved.

A) HUB AND CRANK REPLACEMENT

Tools Needed:

Two Wrenches
Hammer

Parts Needed:

Hub Tube
Hub Star
Hub Blades
Crank

- 1) Being able to lean the boat against a wall is helpful. Two people will also help.
- 2) Using two wrenches, remove the nylock nuts off the bolts from the under side of the boat where the hub and crank meet. Note: You may need to use a penetrating oil or Liquid Wrench to help loosen the nut.
- 3) Once the nuts are removed tap the end of the bolt with a hammer to push it through and remove the bolts.
- 4) From the deck side, pull on the crank to slide out of the hub. If cranks are difficult to remove use penetrating oil or Liquid Wrench and thoroughly soak the area where the crank slides into the hub.
- 5) From the deck side, pull cranks out of bushing gently lifting crank upwards to remove past walls of footwell.
- 6) If replacing bushings - See *Procedure B*.
- 7) Remove any deposits on the crank using a scouring pad if they are not being replaced.
- 8) Using a Q-Tip and a jar of petroleum jelly, coat the end of the crank with vaseline and the inside of the crank bushing. This will make assembly easier.
- 9) Slide the hub tube thru the star and align the bolt holes with the slots on the star.
- 10) Insert bolts and nuts and tighten.
- 11) Slide both crank assemblies into bushings through the deck side.
- 12) Be sure the flat side of the bottom blade is facing the back of the boat. While holding hub assembly in position, push the crank into the hub tube and repeat for other side.
- 13) Slide crank into hub tub so that the bolt holes line up and insert bolt through the holes. Make sure crank end pedals are facing opposite directions before inserting the bolt. See Figure 1
- 14) Place nylock nuts on bolts and tighten.
- 15) Refer to *Procedure D* for hub blade installation.

Figure #1

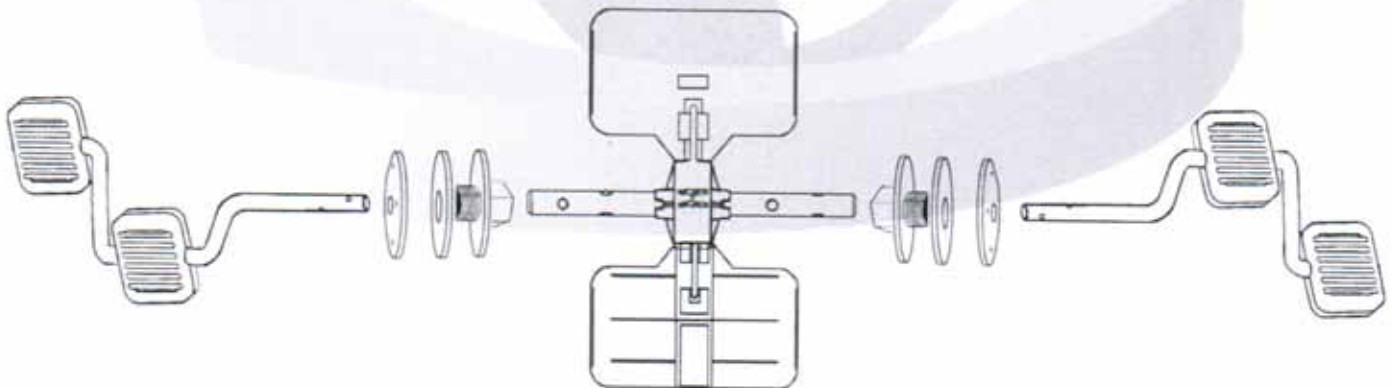

B) CRANK BUSHING REPLACEMENT

Tools Needed:

Adjustable Wrench
Needle Nose Pliers
Phillips Screwdriver
Rubber Mallet or
Small Hammer

Parts Needed:

Crank Bushing Kit

Note: A second person may be required.

- 1) Refer to *Procedure A* for removal of cranks and hub.
- 2) Using an adjustable wrench, unscrew the bushing stud from the underside of the boat.
- 3) Remove cover nut from top side of boat.
- 4) Place gasket on bushing stud and insert from bottom side of boat.
- 5) Thread the cover nut on the stud from the top side.
- 6) Hold the cover nut secure using needle nose pliers or a phillips screwdriver placed in the holes of the cover nut.
- 7) Tighten the bushing stud using the adjustable wrench from the bottom side of boat.
- 8) Do not overtighten as this can damage the threads.
- 9) Refer to *Procedure A* for installation of cranks and hub.

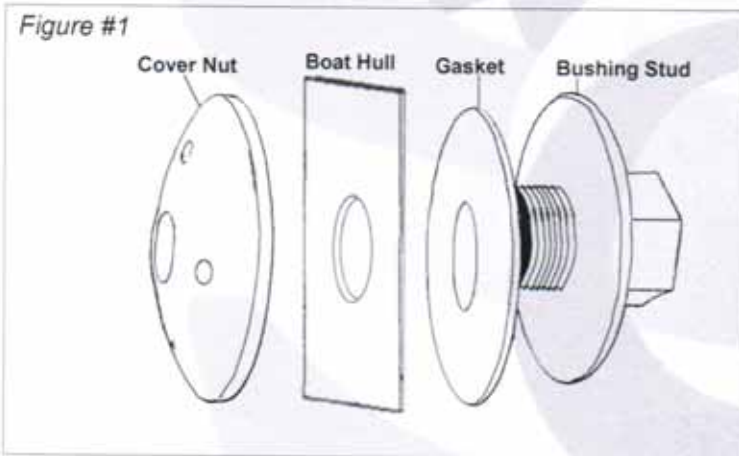

C) PEDAL REPLACEMENT

Tools Needed:

Flat Head Screwdriver

Parts Needed:

2 Pedal Halves

- 1) The pedal assembly consists of (2) half pedals.
- 2) Remove old pedal if present by prying the 2 halves apart with a screwdriver.
- 3) Place 1/2 half of the pedal on each side of the crank
- 4) Line up the locking tabs and press together
- 5) If pedal halves won't click shut use a little force till you hear a click sound.

D) HUB BLADE REPLACEMENT

Tools Needed:

Flat Head Screwdriver

Parts Needed:

Hub Blade(s)

- 1) Remove the old blade from the hub star by inserting a flathead screwdriver as shown in Figure #1.
- 2) Insert the new blade on the star. Note the small round locking pin as shown in Figure #2 determines the proper blade direction.

Figure #1

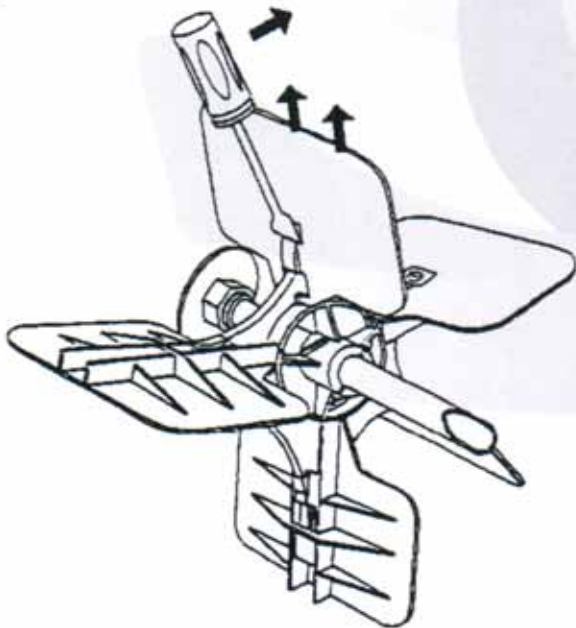
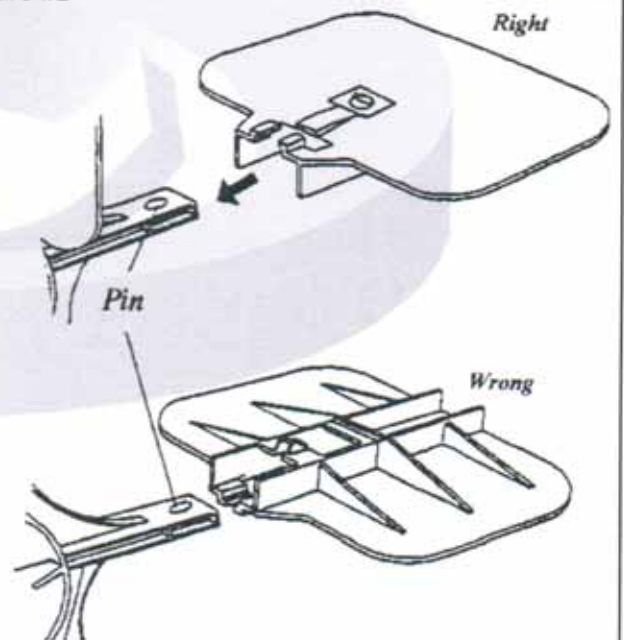

Figure #2



E) STEERING ROD REPLACEMENT

Before beginning the installation, tilt pedalboat on it's side on a non-damaging surface.

Tools Needed:

Screwdriver
Pliers

Parts Included in the Universal Rod Kit:

1 - Steering Rod
2 - Star Washers

- 1) Remove the star washers from both ends of the old steering rod if present
- 2) Remove the bolt and nut holding the steering handle to the steering tube. See Figure #1
- 3) Slide the steering tube out of the boat.
- 4) Following the hook, rotate the steering elbow down and off the old steering rod. See Figure #2
- 5) Following the shape of the hook, remove the old steering rod from the rudder. See Figure #3
- 6) Insert the new steering rod into the rudder first in reverse of step 5.
- 7) Insert the steering elbow onto the steering rod and slide the steering tube back into the boat.
- 8) Be sure steering elbow connection is on the same side as the rudder connection. See Figure #4
- 9) Line up holes in the steering tube and steering handle and re-install the nut and bolt.
- 10) Place one star washer on each end of steering rod. See Figure #5

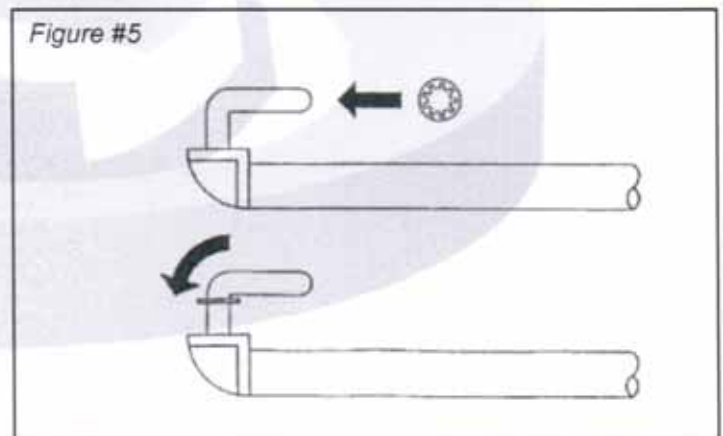
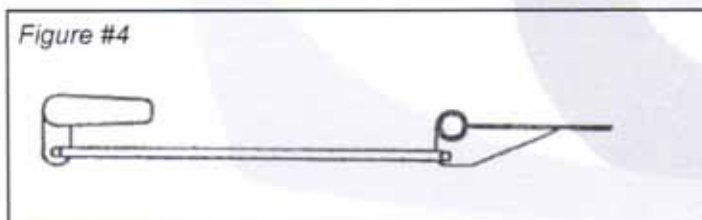
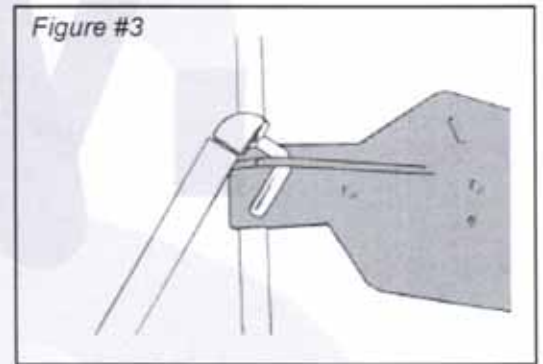
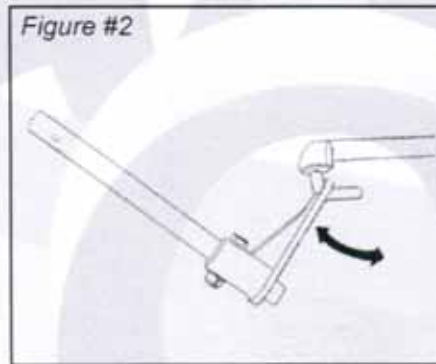
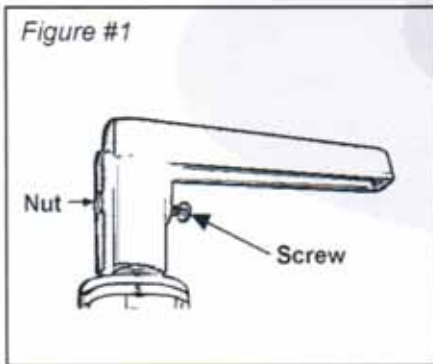

F) RUDDER BLADE / POST REPLACEMENT

Tools Needed:

Allen Wrench
Pliers

Parts Needed:

1 - Rudder Post
1 - Rudder

NOTE: The rudder post is made of aluminum on some models and plastic on others.

1) Plastic rudder post instructions:

- a) Remove the locking tab by pulling out with pliers. See Figure #1
- b) Remove the post by squeezing the ends and pulling straight out.

Aluminum rudder post instructions:

- a) If there is a collar with a set screw, loosen the set screw and remove the collar.
- b) If there is no collar, carefully cut the plastic cap off the end of the post.

2) Slide the post out of the boat and also out of the rudder.

Rudder replacement:

- 3) Remove the locking star washer from the steering rod and rotate the rudder off the steering rod. See Figure #2
- 3) Insert the steering rod thru the new rudder and install the locking star washer. Be sure the steering rod connections for the steering elbow and rudder are on the same side - see Figure #3

Assembly:

- 4) Slide the post thru the rudder. Note the plastic cap on the new post goes next to the rudder.
- 3) Slide the post thru the boat and place the collar over the post.
- 4) Tighten the set screw on the collar with the allen wrench.
- 5) The completed assembly should look like Figure #4.

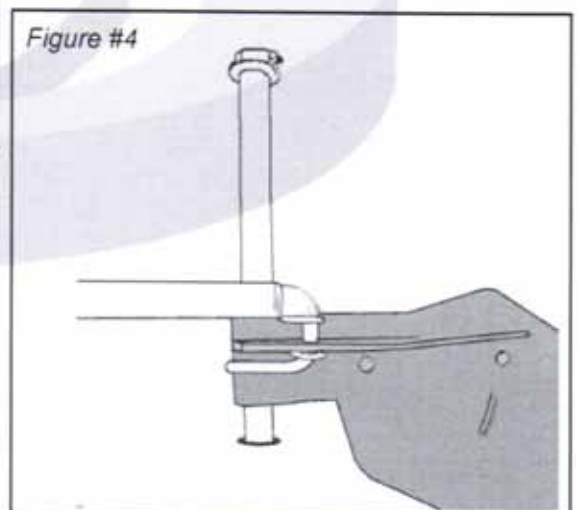
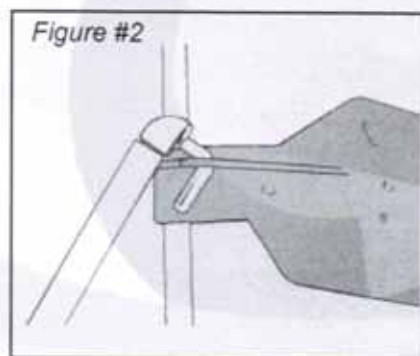
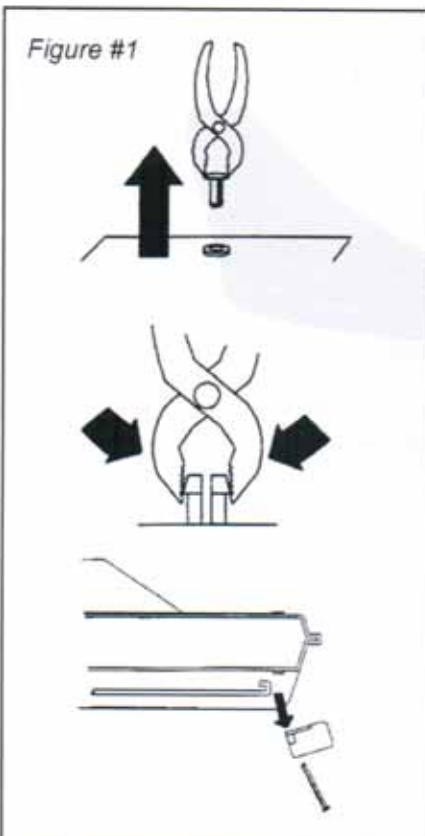

G) THRU-HULL BUSHING REPLACEMENT

Tools Needed:

Large Pliers
Screwdriver

Parts Included in Kit:

Thru-hull Bushing

- 1) Disconnect and remove tube that passes thru the bushing. See procedure for either rudder post or steering tube.
- 2) Remove nut from bottom of thru-hull bushing.
- 3) Grasp the top of the bushing and unscrew from internal nuts.
- 4) Remove bushing from boat.
- 5) Remove all three nuts from new bushing. Note that the top nut is a larger thread.
- 6) Place large gasket on bushing and insert from top side of boat.
- 7) Place small gasket on bottom side of bushing and screw on one small nut.
- 7) Tighten nut until snug. Do not overtighten as this will damage the threads.
- 8) Insert and reconnect the tube removed in step 1.



H) STEERING ELBOW REPLACEMENT

Tools Needed:

2 Wrenches

Parts Needed:

Steering Elbow

Bolt, nut and washer

- 1) Remove bolt from old steering elbow.
- 2) Remove steering elbow from steering tube.
- 3) Remove steering rod from steering elbow.
- 4) Attach steering rod to new steering elbow. See Figure #1
- 5) Place steering elbow on steering tube making sure that the steering rod connections for the elbow and rudder are on the same side. See Figure #2
- 6) Align holes in elbow and steering tube and insert bolt.
- 7) Tighten nut using two wrenches.

Figure #1

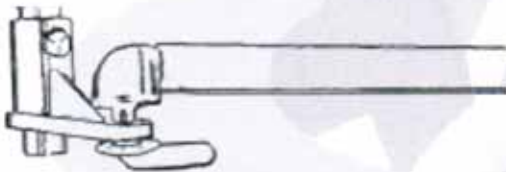

Figure #2

